

DO NOT WRITE IN THIS AREA

DO NOT WRITE IN THIS AREA

DO NOT WRITE IN THIS AREA

Answer ALL TWENTY FIVE questions.

Write your answers in the spaces provided.

You must write down all the stages in your working.

- 1 Nav found the following table that shows the age, in years, of each of seven cities.

City	Age (years)
Cadiz	3124
Suzhou	2534
Jenin	4469
Istanbul	2704
Nanjing	2516
Gaziantep	5669
Alexandria	2351

- (a) Write down the name of the city with the greatest age.

Gaziantep

(1)

- (b) Write the number 2534 in words.

Two thousand five hundred and thirty four

(1)

- (c) Write the number 2351 correct to the nearest ten.

2350 ↑

2360

2350

(1)

- (d) Work out the difference between the age of Cadiz and the age of Nanjing.

3124

2516

608

years

(1)

A millennium is 1000 years.

- (e) What is the age of Jenin in whole millennia?

4469

4

millenniums

(1)

(Total for Question 1 is 5 marks)



P 6 8 7 9 5 A 0 3 2 8

2 (a) Simplify $12a + 3a - 7a$

$$15a - 7a =$$

$$8a$$

(1)

(b) Simplify $8 \times 3b$

$$8 \times 3 = 24$$

$$24b$$

(1)

(c) Solve $\frac{c}{3} = 9$

$$\times 3 \quad \frac{c}{3} = 9 \times 3$$

$$c = 27$$

$$c = 27$$

(1)

(Total for Question 2 is 3 marks)

3 Here is a probability scale.

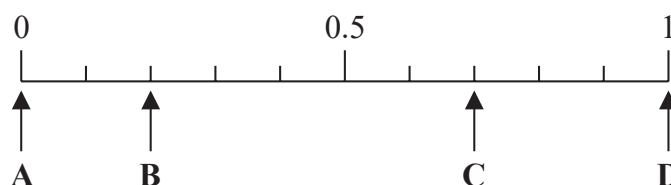

In a fruit bowl, there are only

3 bananas
7 pears

$$\text{TOTAL} = 10$$

$$\frac{7}{10}$$

Shimon is going to take at random one of the fruits from the bowl.

(a) Write down the letter of the arrow that points to the probability that Shimon takes

(i) a pear,

$$\frac{7}{10}$$

$$C$$

(1)

(ii) a grape.

$$0$$

$$A$$

(1)

Emma has some carrots, some potatoes and some onions in a bag.

She says that the probability of taking at random a carrot from the bag is 1.4

Emma is not correct.

(b) Explain why.

The combined probability of taking each item cannot be bigger than 1.

(1)

(Total for Question 3 is 3 marks)



4 Here is a polygon.

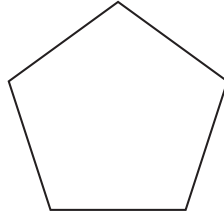

(a) Write down the mathematical name of this polygon.

pentagon
(1)

Here is a scale.

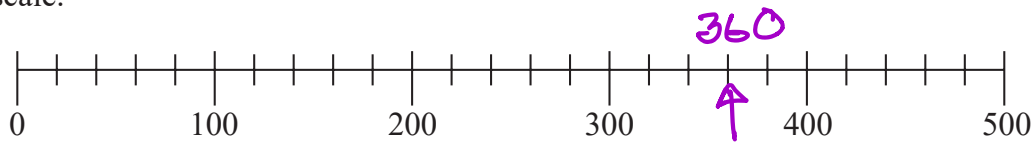

(b) On the scale, mark with an arrow (↑) the number 360

(1)

Here is a clock face.

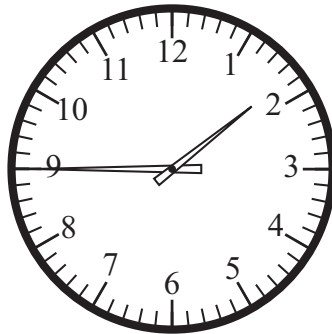

(c) Write down the time shown on the clock face.

1:45

(1)

(d) Complete the following sentence by writing a suitable metric unit on the dotted line.

The length of a pen is 16 centimetres (or cm)

(1)

(Total for Question 4 is 4 marks)



5 Here is a list of numbers.

3 6 7 8 11 25 27

(a) From the numbers in the list, write down

(i) an even number

8 or 6

(1)

(ii) a multiple of 9

9, 18, 27
x x ✓

27

(1)

(iii) a square number

1 4 9 16 25
x x x x ✓

25

(1)

(iv) a prime number

2 3 7 8 11
x ✓ ✓ x ✓

3, 7 or 11

(1)

(b) Use brackets to make the statement correct.

You may use more than one pair of brackets in the statement.

$$(2^2 + 5) \times (2 + 3^2) = 99$$

$4 + 5$ $2 + 9$
 9×11 ✓

(1)

(Total for Question 5 is 5 marks)

6

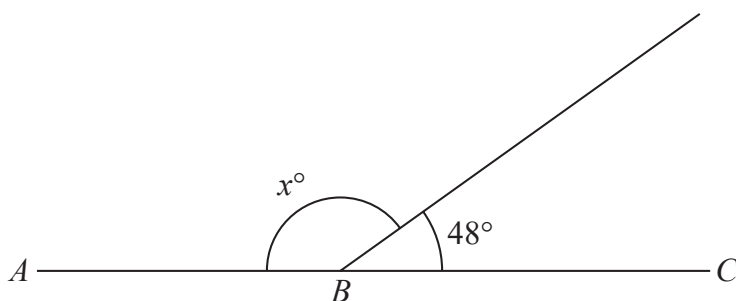

Diagram NOT accurately drawn

ABC is a straight line.

(a)(i) Work out the value of x

$$180 - 48 = 132$$

$$x = 132$$

(1)

(ii) Give a reason for your answer to (i)

Angles that meet at a point on a straight line add to 180°

(1)



Question 6 continued

Diagram NOT accurately drawn

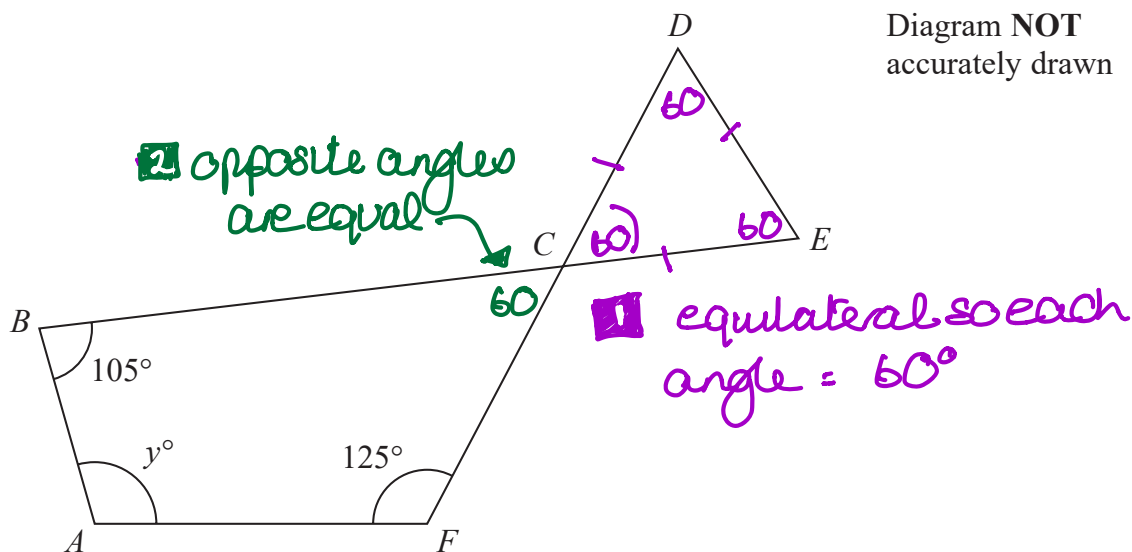

CDE is an equilateral triangle.

$ABCF$ is a quadrilateral.

BCE and DCF are straight lines.

- (b) Work out the value of y
You must show your working.

$$ABCF \rightarrow \text{sum} = 360^\circ$$

$$105 + 125 + 60 = 290$$

$$y = 360 - 290 = 70^\circ$$

$$y = \dots 70^\circ \dots$$

(3)

(Total for Question 6 is 5 marks)



7 Sandeep buys some flowers.
He has 5000 rupees to spend.

He buys 6 carnations at 220 rupees each.
He also buys some roses at 295 rupees each.

Sandeep should receive 140 rupees in change from his 5000 rupees.

Work out how many roses Sandeep buys.

$$6 \text{ carnations} = 6 \times 220 = 1320$$

$$\text{Change} = 140$$

$$\text{so spends } 5000 - 140 = 4860$$

$$\text{Roses} \Rightarrow 4860 - 1320 = 3540$$

$$3540 \div 295$$

$$= 12$$

12

(Total for Question 7 is 4 marks)



8 (a) Simplify $12g - 8e - 5g + 6e$

$$12g - 5g - 8e + 6e$$
$$7g - 2e$$

$$7g - 2e$$

(2)

$$A = 3b - 5c$$

(b) Work out the value of A when $b = 12$ and $c = 4$

$$A = 3 \times 12 - 5 \times 4$$
$$= 36 - 20$$
$$= 16$$

$$A = 16$$

(2)

(c) Solve $4p + 9 = 24$

$$4p + 9 = 24$$
$$\begin{array}{r} 4p + 9 = 24 \\ -9 \quad -9 \end{array}$$

$$4p = 15$$
$$\begin{array}{r} 4p = 15 \\ \div 4 \quad \div 4 \end{array}$$

$$p = \frac{15}{4}$$

$$p = \frac{15}{4} \text{ or } 3\frac{3}{4} \text{ or } 3.75$$

(2)

(Total for Question 8 is 6 marks)



- 9 ABC is a triangle.
 $AB = 8\text{ cm}$, $AC = 6\text{ cm}$ and $BC = 9\text{ cm}$.

Use a ruler and compasses to construct the triangle ABC .
The side AB has been drawn for you.
You must show all your construction lines.

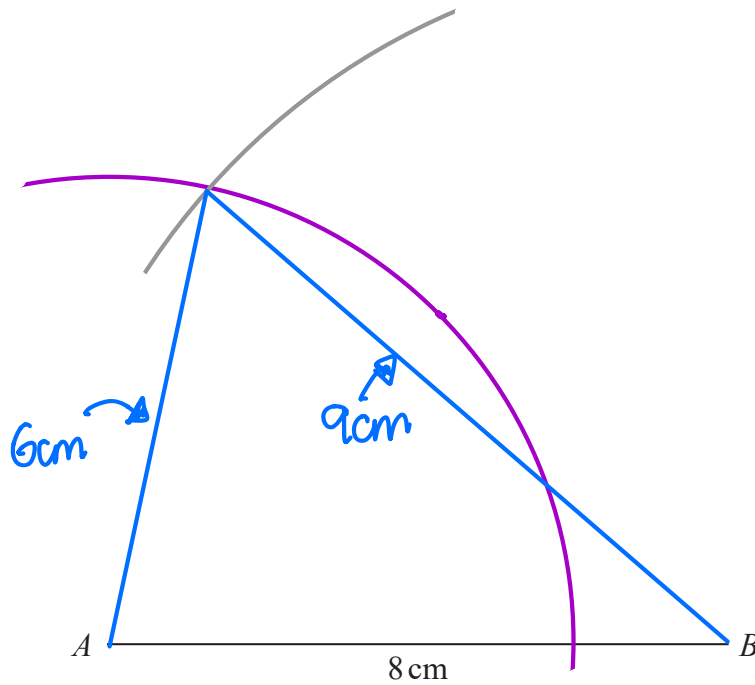

(Total for Question 9 is 2 marks)

DO NOT WRITE IN THIS AREA

DO NOT WRITE IN THIS AREA

DO NOT WRITE IN THIS AREA



10 Anjali wants to go on a boat at the seaside.

At the seaside there are 20 boats.

Of these boats

2 are white

5 are blue

7 are green

6 are yellow

} 20

Anjali selects at random one of these boats.

Write down the probability that she selects

(i) a green boat,

$$\frac{7}{20}$$

(1)

(ii) a white boat or a yellow boat.

2

6

$$\frac{8}{20}$$

(2)

(Total for Question 10 is 3 marks)



11 Johan wants to make some small cakes.

He finds a recipe that says he needs 360 grams of flour to make 15 small cakes.

Johan has 0.85 kg of flour. = 850g

Johan works out how much flour he would need to make 38 small cakes, using the information given in the recipe.

Does Johan have enough flour, according to the recipe, to make 38 small cakes?
Show your working clearly.

$$360\text{g} = 15 \text{ cakes}$$

$$\div 15$$

$$24\text{g} = 1 \text{ cake}$$

$$\times 38$$

$$912\text{g} = 38 \text{ cakes}$$

He does not have enough

$$912\text{g} > 850\text{g}$$

(Total for Question 11 is 4 marks)

DO NOT WRITE IN THIS AREA

DO NOT WRITE IN THIS AREA

DO NOT WRITE IN THIS AREA



- 12 The table gives information about the number of gold stars won by each of 25 students in class 7T last week.

Number of gold stars		Number of students	
0	x	6	= 0
1	x	5	= 5
2	x	4	= 8
3	x	7	= 21
4	x	3	= 12
		<u>25</u>	

- (a) Work out the mean number of gold stars won.

$$0 + 5 + 8 + 21 + 12 = 46$$

$$46 \div 25 = 1.84$$

1.84

(3)

A student in class 8R is to be chosen at random.

The probability that this student won at least one gold star last week is 0.39

- (b) Work out the probability that this student did **not** win at least one gold star last week.

$$P(\text{win}) = 0.39$$

$$P(\text{not win}) = 1 - 0.39 \\ = 0.61$$

0.61

(1)

(Total for Question 12 is 4 marks)



13 On the grid, draw the graph of $y = -2x + 3$ for values of x from -1 to 5

$$x = 5 \quad y = -2 \times 5 + 3 = -10 + 3 = -7$$

$$x = 0 \quad y = 3$$

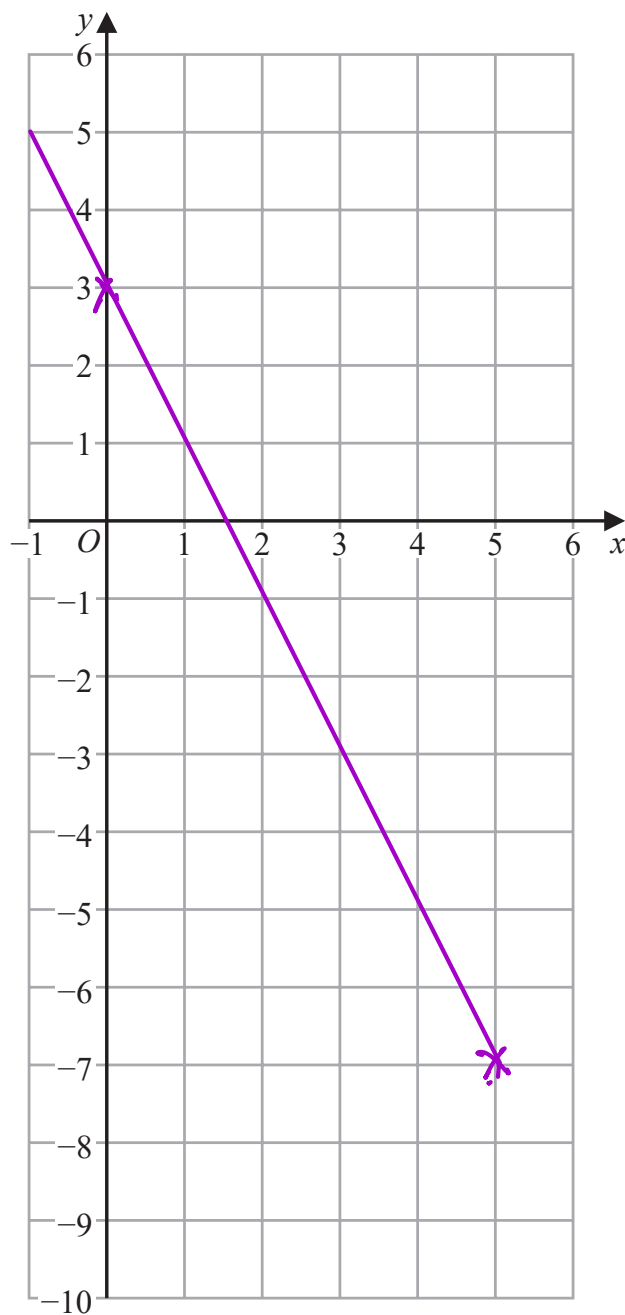

(Total for Question 13 is 3 marks)

DO NOT WRITE IN THIS AREA

DO NOT WRITE IN THIS AREA

DO NOT WRITE IN THIS AREA



14 In 2001, the total number of cars produced in the world was 39.8 million.

In 2006, the total number of cars produced in the world was 10.1 million greater than the total number produced in 2001

- (a) Express 10.1 million as a percentage of 39.8 million.
Give your answer correct to one decimal place.

$$\frac{10.1}{39.8} \times 100 = 25.37\dots$$

$$= 25.4$$

$$\dots\dots\dots 25.4 \dots\dots\dots \%$$

(2)

In 2011, the total number of cars produced in the world was 59.9 million.

In 2016, the total number of cars produced in the world was 21% greater than the total number produced in 2011

In 2016, the total number of cars produced in the world was N million.

- (b) Work out the value of N .
Give your answer correct to the nearest whole number.

2011	2016	
59.9	N	
	↘ +21%	59.9×1.21
		$= 72.479$

$$N = \dots\dots\dots 72 \dots\dots\dots$$

(3)

(Total for Question 14 is 5 marks)



- 15 The diagram shows a shape $ABCDEFG$ made from a square $ABDF$ and three identical isosceles triangles BCD , DEF and FGA .

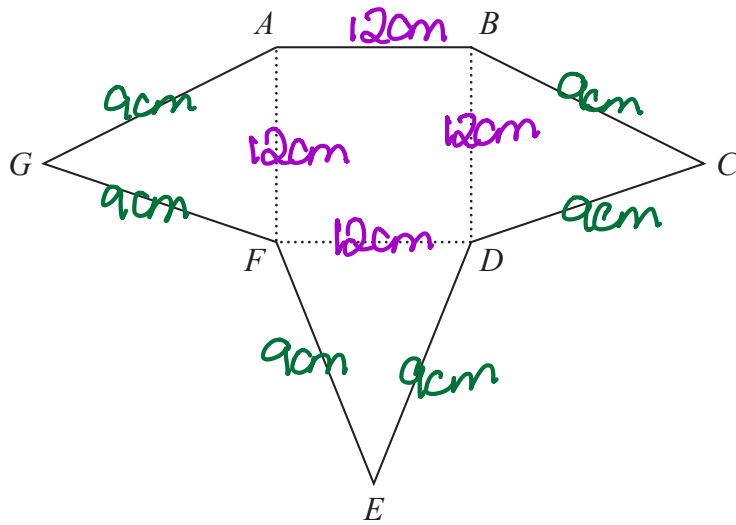

Diagram NOT accurately drawn

The perimeter of the square $ABDF$ is 48 cm.
 The perimeter of each isosceles triangle is 30 cm.
 Work out the perimeter of the shape $ABCDEFG$.

$$\begin{aligned} \text{Perimeter of square} &= 48 \\ \text{so each side length} &= 12 \text{ cm} \end{aligned}$$

$$\begin{aligned} \text{Each } \triangle \text{ perimeter} &= 30 \\ 30 - 12 &= 18 \\ \text{other sides} &= \frac{18}{2} = 9 \text{ cm} \end{aligned}$$

$$\begin{aligned} \therefore \text{Shape} &= 9 \times 6 + 12 \\ &= 54 + 12 \end{aligned}$$

..... 66 cm

(Total for Question 15 is 4 marks)



16 Here are the first five terms of an arithmetic sequence.

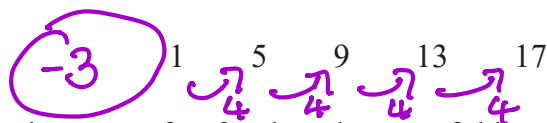

(a) Find an expression, in terms of n , for the n th term of this sequence.

$$4n - 3$$

$$\underline{4n - 3}$$

(2)

The n th term of another arithmetic sequence is $3n + 5$

(b) Find an expression, in terms of m , for the $(2m)$ th term of this sequence.

$$\begin{aligned} 3(2m) + 5 \\ = 6m + 5 \end{aligned}$$

$$\underline{6m + 5}$$

(1)

(Total for Question 16 is 3 marks)



17 Here is a biased 4-sided spinner.

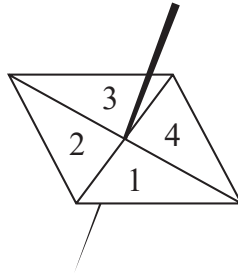

The table gives the probabilities that, when the spinner is spun once, it will land on 1 or it will land on 3

Number	1	2	3	4
Probability	0.26	0.28	0.18	0.28

same.

The probability that the spinner will land on 2 is equal to the probability that the spinner will land on 4

Ravina is going to spin the spinner a number of times.

Ravina works out that an estimate for the number of times the spinner will land on 3 is 45

Work out an estimate for the number of times the spinner will land on 4

$$0.26 + 0.18 = 0.44$$

$$1 - 0.44 = 0.56$$

$$0.56 \div 2 = 0.28$$

$$0.18 = 45 \text{ times}$$

$$\div 0.18$$

$$1 = \underline{250 \text{ total.}}$$

$$\text{so } 0.28 \times 250 = 70$$

70

(Total for Question 17 is 4 marks)



- 18 (a) Find the highest common factor (HCF) of 56 and 84
Show your working clearly.

$$56 = 2 \times 2 \times 2 \times 7$$

$$84 = 2 \times 2 \times 3 \times 7$$

$$\begin{aligned} \text{HCF} &= 2 \times 2 \times 7 \\ &= 28 \end{aligned}$$

28

(2)

- (b) Find the lowest common multiple (LCM) of 60 and 72
Show your working clearly.

$$60 = 2 \times 2 \times 3 \times 5$$

$$72 = 2 \times 2 \times 2 \times 3 \times 3$$

$$\text{HCF} = 2 \times 2 \times 3 = 12$$

$$\begin{aligned} \text{LCM} &= 12 \times 5 \times 2 \times 3 \\ &= 360 \end{aligned}$$

360

(2)

(Total for Question 18 is 4 marks)



19 The diagram shows parts of three regular polygons, A, B and C, meeting at a point.

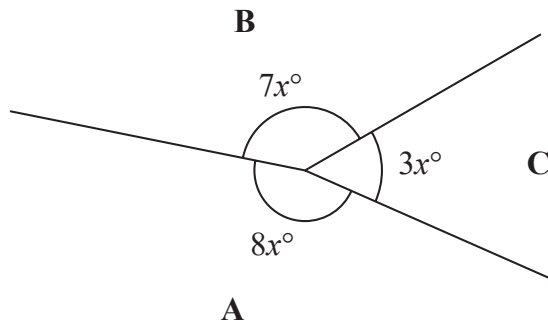

Diagram NOT accurately drawn

Polygon B has n sides.

Work out the value of n .

$$7x + 3x + 8x = 360$$

$$18x = 360$$

$$\therefore x = \frac{360}{18} = 20^\circ$$

$$\text{interior angle of B} = 7 \times 20 = 140^\circ$$

$$\text{so exterior angle} = 180 - 140 = 40^\circ$$

$$\text{Number of sides} = \frac{360}{40} = 9$$

$$n = \dots 9 \dots$$

(Total for Question 19 is 4 marks)

DO NOT WRITE IN THIS AREA

DO NOT WRITE IN THIS AREA

DO NOT WRITE IN THIS AREA



20 (a) Expand and simplify $(n - 6)(n + 4)$

$$\begin{array}{l} n \times n = n^2 \\ n \times 4 = 4n \\ -6 \times n = -6n \\ -6 \times 4 = -24 \end{array} \left. \vphantom{\begin{array}{l} n \times n \\ n \times 4 \\ -6 \times n \\ -6 \times 4 \end{array}} \right\} -2n$$

$$\frac{n^2 - 2n - 24}{(2)}$$

(b) Solve $2x - 3 = \frac{3x - 5}{4}$

Show clear algebraic working.

$$4(2x - 3) = 3x - 5$$

$$8x - 12 = 3x - 5$$

$$5x = 7$$

$$x = \frac{7}{5}$$

$$x = \frac{7}{5} \text{ or } 1\frac{2}{5} \text{ or } 1.4$$

(3)

(Total for Question 20 is 5 marks)



21 Asha bought an apartment.

The table gives information about the value of apartments, in euros, and the annual service charge band.

Value (x euros)	Service charge band
$x \geq 700\,000$	A
$600\,000 \leq x < 700\,000$	B
$500\,000 \leq x < 600\,000$	C
$400\,000 \leq x < 500\,000$	D
$0 < x < 400\,000$	E

← 2021

In 2021, the value of Asha's apartment was 634 400 euros.

The value of Asha's apartment had increased by 4% from its value in 2020

- (a) Has the annual service charge band changed for Asha's apartment?
Show your working clearly.

$$2021 \Rightarrow 634\,400 = 104\% \\ 6100 = 1\% \quad \div 104 \\ \times 100$$

$$2020 \Rightarrow 610\,000 = 100\%$$

No, it was 610,000 which is still Band B

(3)

Pam bought a boat.

In each year after Pam bought the boat, the value of the boat depreciated by 15%

- (b) Work out the total percentage by which the value of the boat had depreciated by the end of the second year after Pam bought the boat.

$$1 \times 0.85 \times 0.85 = 0.7225$$

$$1 - 0.7225 = 0.2775$$

$$0.2775 = 27.75\%$$

27.75 %

(3)

(Total for Question 21 is 6 marks)



22 A cylinder is placed on the ground.

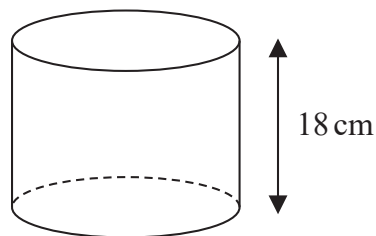

Diagram **NOT**
accurately drawn

The height of the cylinder is 18 cm.

The force exerted by the cylinder on the ground is 72 newtons.

The pressure on the ground due to the cylinder is 1.4 newtons/cm²

$$\text{pressure} = \frac{\text{force}}{\text{area}}$$

Work out the volume of the cylinder.

Give your answer correct to 3 significant figures.

$$p = 1.4 \text{ N/cm}^2$$

$$F = 72 \text{ N}$$

$$A = ?$$

$$1.4 = \frac{72}{A}$$

$$A = \frac{72}{1.4}$$

$$= 51.428\dots$$

$$\text{Volume} = 51.428\dots \times 18$$

$$= 925.714\dots$$

$$\text{3.s.f.} \Rightarrow 926$$

$$\dots\dots\dots 926 \dots\dots\dots \text{cm}^3$$

(Total for Question 22 is 4 marks)



23 (a) Write 0.000089 in standard form.

$$8.9 \times 10^{-5}$$

(1)

(b) Write 8.34×10^4 as an ordinary number.

$$8.3400$$

$$83400$$

(1)

(Total for Question 23 is 2 marks)

24 (a) Simplify $8 \times (4t)^0$

$$\uparrow = 1$$

$$8 \times 1 = 8$$

$$8$$

(1)

$$x^6 \div x^{-5} = x^p$$

(b) Find the value of p

$$x^{6-(-5)} = x^{6+5}$$

$$= x^{11}$$

$$p = 11$$

(1)

(c) Simplify fully $(2k^2m^4)^3$

$$2^3 k^{2 \times 3} m^{4 \times 3}$$

$$= 8k^6m^{12}$$

$$8k^6m^{12}$$

(2)

(Total for Question 24 is 4 marks)



DO NOT WRITE IN THIS AREA

DO NOT WRITE IN THIS AREA

DO NOT WRITE IN THIS AREA

25 Two circles, C_1 and C_2 , are drawn on a centimetre grid, with a scale of 1 cm for 1 unit on each axis.

The centre of circle C_1 is at the point with coordinates $(-1, 3)$ and the radius of C_1 is 13 cm.

The centre of circle C_2 is at the point with coordinates $(7, 18)$ and the radius of C_2 is 6 cm.

(a) Work out the distance between the centre of C_1 and the centre of C_2

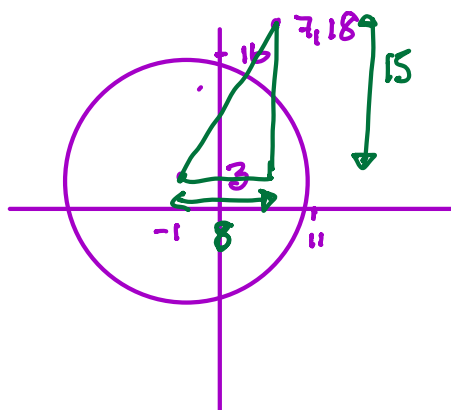

$$\begin{aligned}
 &\text{Centre } C_1 \text{ to } C_2 \\
 &= \sqrt{8^2 + 15^2} \\
 &= \sqrt{64 + 225} \\
 &= \sqrt{289} \\
 &= 17
 \end{aligned}$$

..... 17 cm
(3)

(b) Explain why circle C_1 intersects circle C_2

They overlap $13 + 6 = 19$ $19 > 17$

(1)

(Total for Question 25 is 4 marks)

TOTAL FOR PAPER IS 100 MARKS

